

 BURRIS®

# ***SPEEDBEAD***

## Installation Instructions

Stoeger

Item 300252

• 3500



## SpeedBead - Stoeger - 3500

Be sure the gun is empty. It is best if you adjust the stock fit (cast and drop) before mounting the SpeedBead. Your owners manual has excellent instructions for doing this. It is advisable to be familiar with these instructions before mounting a SpeedBead under any circumstances.

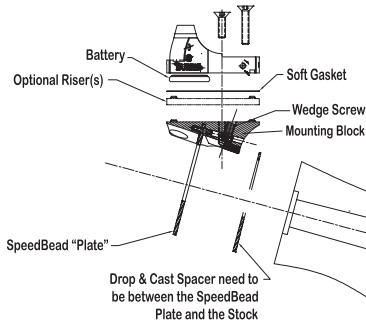

# BURRIS®

1. First remove the butt pad with a Phillips screw driver.

2. Remove the Stock Nut and Stock using a 15mm socket wrench with extension. Note the lettering that faces rearwards on your preferred **Drop & Cast Spacer**.

3. Place the Drop & Cast Spacer against the back of the plate of the SpeedBead mount with the correct lettering facing rearward. Slide the forward facing pins of the Drop & Cast Spacer through the holes of the **SpeedBead Plate**. (Note: The Drop & Cast spacers will need to be between the SpeedBead Plate and the stock.)

4. Place the SpeedBead and **Drop & Cast Spacer** against the back of the receiver. Slide the Stock back on to the stud assembly of the receiver and under the SpeedBead back. Squeeze the stock up in to the foam of the SpeedBead as the Stock goes up against the Plate. Reinstall the stock nut with its washers and plate. (Refer to the owner's manual if

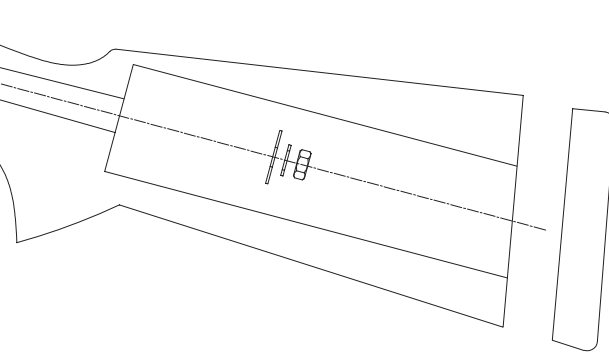

necessary.) Be sure to tighten the nut securely so there no gaps between the Receiver, SpeedBead Plate, Drop & Cast Spacer, and Stock. Reinstall the Butt Pad also.

5. Looking at the top surface of the SpeedBead mounting wedge, you will notice a threaded hole toward the rear. Insert the long leg of the provided hex wrench into the screw that is inside that hole and firmly tighten it using the short leg. (Using the short leg of the wrench as the lever will prevent you from over tightening the screw.)

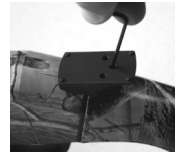

6. Place the SpeedBead Gasket Plate on the mount rubber side up. Mount the FastFire II sight on the SpeedBead mount using the provided short screws and lock washers. Don't forget the battery. The same hex wrench will engage these screws.



## 7. SpeedBead Base Alignment

Using the hex wrench, tighten the **Wedge Screw**. Slightly snug is plenty tight and will prevent scarring of the stock beneath the SpeedBead mount.

Position the **soft gasket** on top of the mounting block or optional riser, aligning the holes to the pins.



Turn on the FastFire sight and see where it's Red Dot is located relative to the barrel and its bead. Use the provided screwdriver to FIRST loosen the FastFire lock screws, then adjust the Red Dot to be "on" the barrel bead. You will want to be looking right along the barrel rib when you do this. That will normally mean the Red Dot will be viewed in the lower third of the window. Tighten the lock screws. You are likely very close to zero. We strongly recommend you finish zeroing on a pattern board (or the bench if you are shooting slugs). There are FastFire zeroing instructions in the box.

### Operating Notes:

The SpeedBead system is virtually parallax free. Once sighted-in, no matter where in the window the Red Dot appears, wherever the Red Dot is pointed is where the shot pattern will go. Do not be concerned if the Red Dot is not in the center of the window when shooting. Just get the Red Dot where you want it in relation to the target and take the shot.

**For additional information about the FastFire sight, see the included FastFire II booklet.**